

100 Series Disc Feeder

Typical application of 100 Series:

- A. OC50 Controller
- B. 100 Disc Feeder
- C. Disc

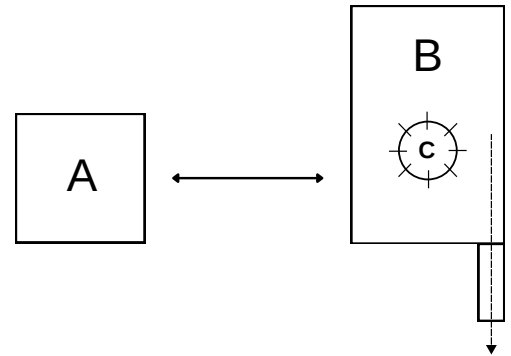

Description

Orbetron's 100 Series Feeders has the most demand due to the versatility of all feeders offered. The design offers a 100mm (4") in diameter feeding disc. The base feeder design is sized to feed low rate feeding applications .01 to 10lb/hr. All rates can vary based upon the density, flowability, and size of the material.

Alike to Orbetron's 50 Series Disc Feeder, the 100 Series allows for easy mounting, it holds unlimited possibilities! No other auger or vibratory feeders can match The 100's capabilities, in terms of size, feeding capability, and repeatability. All of Orbetron's Disc Series Feeders are designed to handle bulk materials ranging from powder to pellets. This rate can vary based upon the density, flowability, and size of the material.

Specifications

- 110/220 Vac single phase 50/60 hz
- Stepper Motor Drive
- Volumetric/Gravimetric Capable (Batch/Continuous)
- Quick Exchange Housing
- Dose Power to Pellet Materials
- Multiple Mounting Capabilities
- Separate Mounted Controls

OC50 Controller

- Separate Mounted Controls
- HMI Color Touchscreen
- PLC Control with I/O for Stepper, DC, or AC Motors

Design

- Standard disc sizes include 24, 12, & 6 holes per revolution. Special disc sizes are designed based upon your feeding needs
- 3D printing technology is utilized to design disc specifications
- High exchange and easy-clean capabilities

Options

- *External Alarm Audible & Light*
- *Spare Station for Easy Changeover*
- *Optional Agitation for Special Materials*
- *Continuous running software*
- *Extension Cable*
- *SS Hopper*
- *Small loader adapter*
- *Multi-component capability up to 4 units*

